

# ZA-J1900 L2C6Motherboard

User Manual

Intel® J1900 2.0GHz/Quad core processor

Issue date: 03/2018

# ZA-J1900 L2C6 Motherboard Configuration Diagram

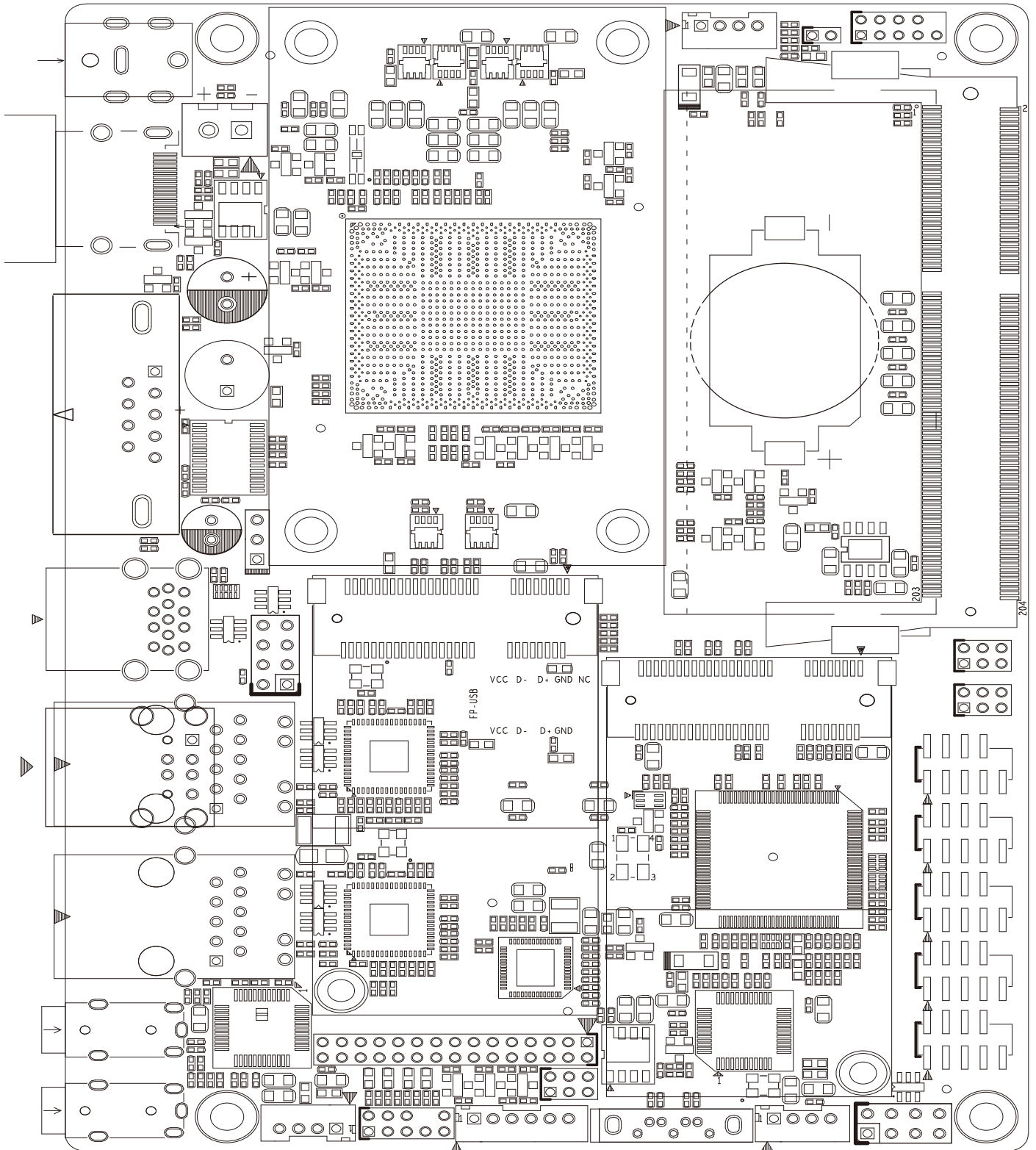

# ZA-J1900 L2C6 Motherboard Diagram

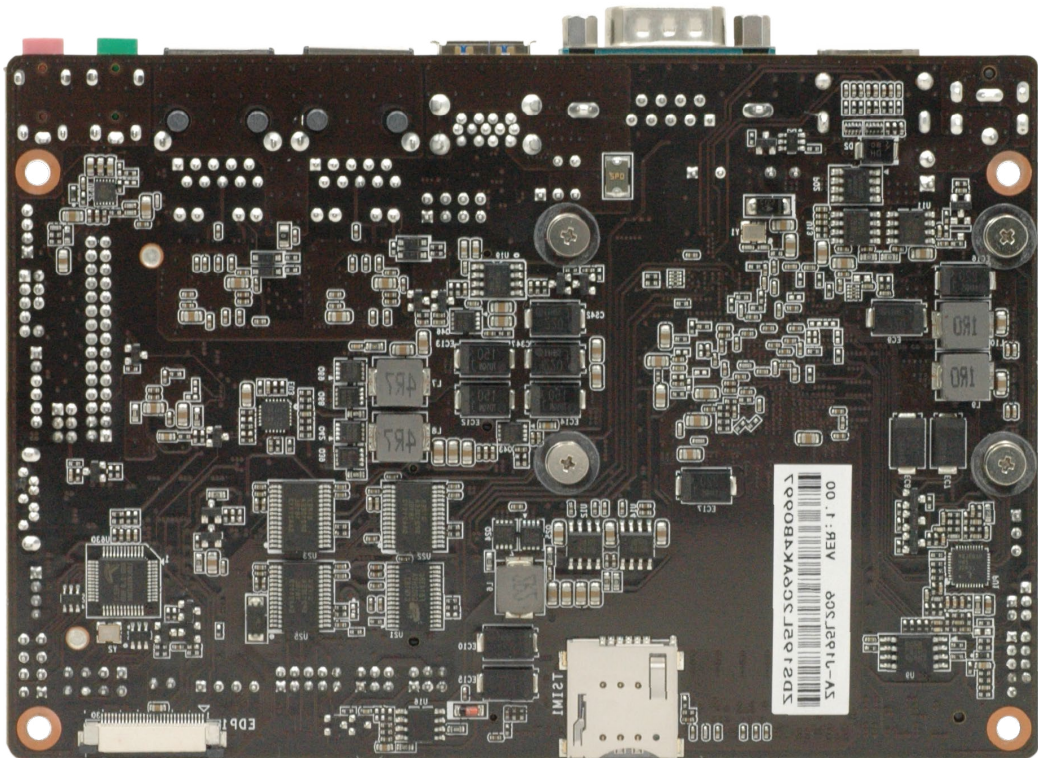
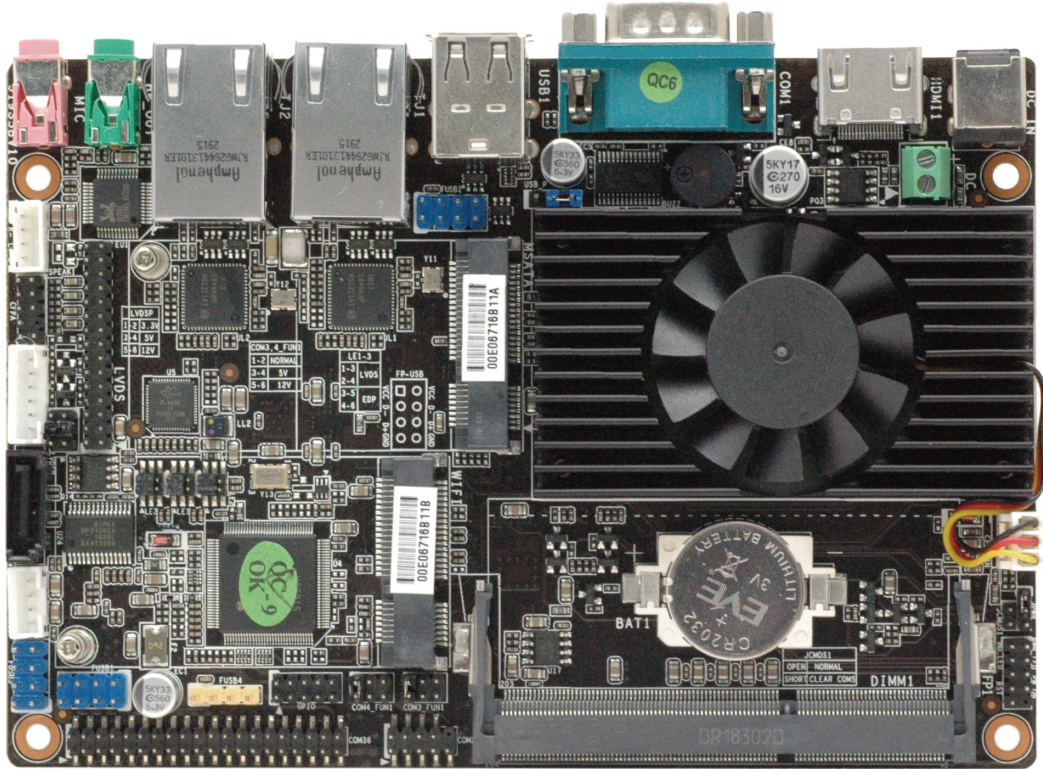





# Motherboard Specification

Size	102mm x 148mm
CPU	Support Intel® J1900 Quad core
Graphics	Intel® HD Graphics
Chipset	J1900
Memory	1*DDR3 1333/1600MHz,Up to 8GB
Internal I/O	3*USB2.0 Pin 6*USB Port 5*COM Pin 2*COM_FUN Pin 1*Front panel Pin 1*CPU Fan 1*2Pin Socke 1*INVERT 1*LVDS Pin 1*LVDSP 1*SATA 1*JSATA 1*EDP 1*TSIM 1*Audio Pin Port (2W/CH)
Rear I/O	1*DC Power Input (12V) 1*HDMI 1*COM 1*USB2.0 1*USB3.0 2*LAN 1* Mic-in/Line-out
BIOS AMI	AMIBIOS,64M bit Flash Memory
MINI_PCIE	1*Support Msata 1*Support WiFi
SATA	1*SATA
LAN	2 Intel WG-I211 Ethernet controllers
Audio	ALC662 Dual Channel Output
Operating System	Windows7 Windows8 Windows10 Linux
H/W Monitoring	System Power Management Temperature Management Voltage Management
Humidity	0% ~ 95% (Relative Humidity,No Condensation)
Temp	-10°C ~ 55°C

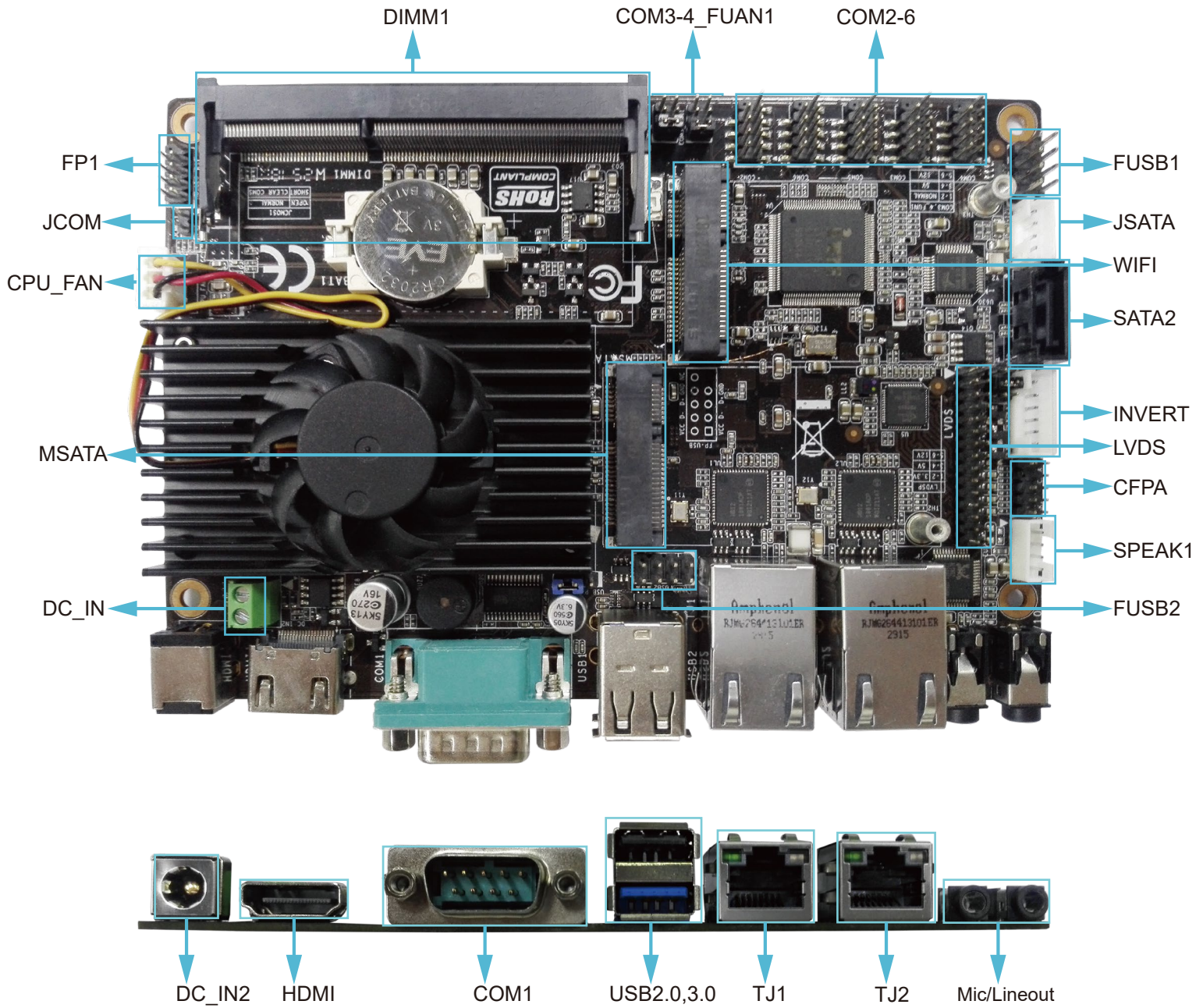

# Motherboard I/O Interface Diagram

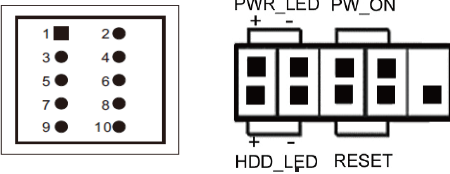
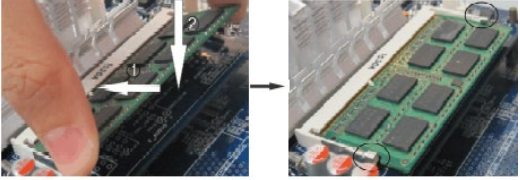

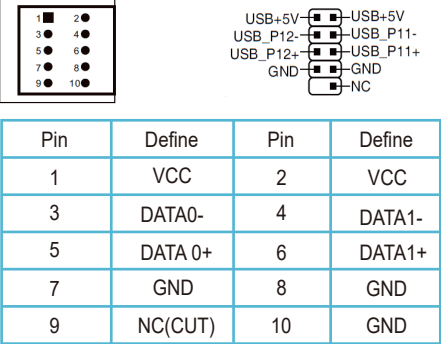
JCOMS1																									
FP1	 <table border="1" data-bbox="802 501 1254 730"> <thead> <tr> <th>Pin</th> <th>Define</th> <th>Pin</th> <th>Define</th> </tr> </thead> <tbody> <tr> <td>1</td> <td>HDD LED+</td> <td>2</td> <td>PWR LED+</td> </tr> <tr> <td>3</td> <td>HDD LED-</td> <td>4</td> <td>GND</td> </tr> <tr> <td>5</td> <td>GND</td> <td>6</td> <td>P_SWIN</td> </tr> <tr> <td>7</td> <td>RESET_GND</td> <td>8</td> <td>GND</td> </tr> <tr> <td>9</td> <td>GND</td> <td></td> <td></td> </tr> </tbody> </table> <p data-bbox="791 757 1278 819">HDD Active LED:1,3    Power Button:6,8 Power LED:2,4        Reset Button:5,7</p>	Pin	Define	Pin	Define	1	HDD LED+	2	PWR LED+	3	HDD LED-	4	GND	5	GND	6	P_SWIN	7	RESET_GND	8	GND	9	GND		
Pin	Define	Pin	Define																						
1	HDD LED+	2	PWR LED+																						
3	HDD LED-	4	GND																						
5	GND	6	P_SWIN																						
7	RESET_GND	8	GND																						
9	GND																								
DIMM1	 <p data-bbox="796 1066 1422 1137">Note: static electricity damages electronic components of a computer or memory, so before following these steps, Be sure to touch the grounded metal objects briefly to remove static electricity from your body.</p>																								
COM_3FUN1 COM_4FUN1	<table border="1" data-bbox="828 1207 1031 1352"> <thead> <tr> <th>PIN</th> <th>Define</th> </tr> </thead> <tbody> <tr> <td>1-2</td> <td>+5V</td> </tr> <tr> <td>3-4</td> <td>DCD</td> </tr> <tr> <td>5-6</td> <td>+12V</td> </tr> </tbody> </table> 	PIN	Define	1-2	+5V	3-4	DCD	5-6	+12V																
PIN	Define																								
1-2	+5V																								
3-4	DCD																								
5-6	+12V																								
COM2~6	<table border="1" data-bbox="833 1408 1275 1637"> <thead> <tr> <th>Pin</th> <th>Define</th> <th>Pin</th> <th>Define</th> </tr> </thead> <tbody> <tr> <td>1</td> <td>DCD</td> <td>2</td> <td>PXD</td> </tr> <tr> <td>3</td> <td>TXD</td> <td>4</td> <td>DTR</td> </tr> <tr> <td>5</td> <td>GND</td> <td>6</td> <td>DSR</td> </tr> <tr> <td>7</td> <td>RTS</td> <td>8</td> <td>CTS</td> </tr> <tr> <td>9</td> <td>RI</td> <td></td> <td></td> </tr> </tbody> </table>	Pin	Define	Pin	Define	1	DCD	2	PXD	3	TXD	4	DTR	5	GND	6	DSR	7	RTS	8	CTS	9	RI		
Pin	Define	Pin	Define																						
1	DCD	2	PXD																						
3	TXD	4	DTR																						
5	GND	6	DSR																						
7	RTS	8	CTS																						
9	RI																								
FUSB1 FUSB2	 <table border="1" data-bbox="833 1794 1275 2013"> <thead> <tr> <th>Pin</th> <th>Define</th> <th>Pin</th> <th>Define</th> </tr> </thead> <tbody> <tr> <td>1</td> <td>VCC</td> <td>2</td> <td>VCC</td> </tr> <tr> <td>3</td> <td>DATA0-</td> <td>4</td> <td>DATA1-</td> </tr> <tr> <td>5</td> <td>DATA0+</td> <td>6</td> <td>DATA1+</td> </tr> <tr> <td>7</td> <td>GND</td> <td>8</td> <td>GND</td> </tr> <tr> <td>9</td> <td>NC(CUT)</td> <td>10</td> <td>GND</td> </tr> </tbody> </table>	Pin	Define	Pin	Define	1	VCC	2	VCC	3	DATA0-	4	DATA1-	5	DATA0+	6	DATA1+	7	GND	8	GND	9	NC(CUT)	10	GND
Pin	Define	Pin	Define																						
1	VCC	2	VCC																						
3	DATA0-	4	DATA1-																						
5	DATA0+	6	DATA1+																						
7	GND	8	GND																						
9	NC(CUT)	10	GND																						

JSATA

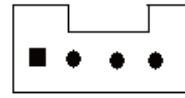

1 2 3 4  
+5V 2. GND 3. GND 4. +12V

WIFI

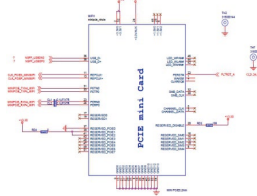

SATA2

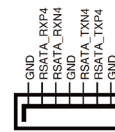

INVERT

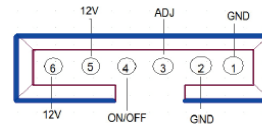

Pin	Define	Pin	Define
1	GND	2	GND
3	ON/OFF	4	ADJ
5	12V	6	12V

LVDS1

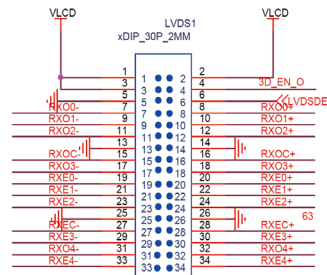

Pin	Define	Pin	Define
1	LCDVDD	2	LCDVDD
3	LCDVDD	4	GND
5	GND	6	GND
7	LVDSA_DATA0N	8	LVDSA_DATA0P
9	LVDSA_DATA1N	10	LVDSA_DATA1P
11	LVDSA_DATA2N	12	LVDSA_DATA2P
13	GND	14	GND
15	LVDSA_CLKN	16	LVDSA_CLKP
17	LVDSA_DATA3N	18	LVDSA_DATA3P
19	LVDSB_TX0N	20	LVDSB_TX0P
21	LVDSB_TX1N	22	LVDSB_TX1P
23	LVDSB_TX2N	24	LVDSB_TX2P
25	GND	26	GND
27	LVDSB_CLKN	28	LVDSB_CLKP
29	LVDSB_TX3N	30	LVDSB_TX3P

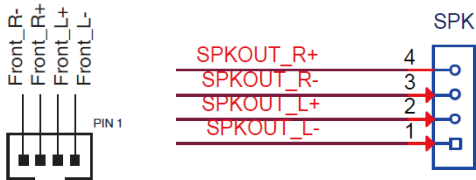
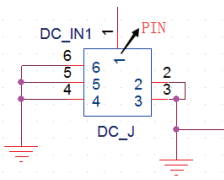
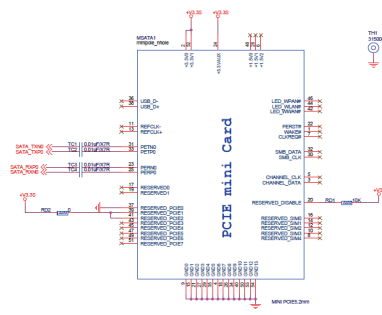
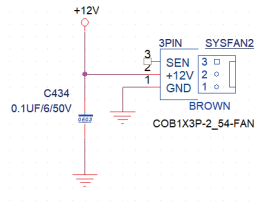
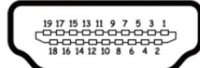
CFPA1	<table border="1"> <thead> <tr> <th>Pin</th> <th>Define</th> <th>Pin</th> <th>Define</th> </tr> </thead> <tbody> <tr> <td>1</td> <td>PROT1L</td> <td>2</td> <td>SENSE1_R</td> </tr> <tr> <td>3</td> <td>AGND</td> <td>4</td> <td>SENSE_S</td> </tr> <tr> <td>5</td> <td>PROT1R</td> <td>6</td> <td>NC</td> </tr> <tr> <td>7</td> <td>PRESENCE#</td> <td>8</td> <td>PORT2L</td> </tr> <tr> <td>9</td> <td>PORT2R</td> <td>10</td> <td>SENSE2_R</td> </tr> </tbody> </table>	Pin	Define	Pin	Define	1	PROT1L	2	SENSE1_R	3	AGND	4	SENSE_S	5	PROT1R	6	NC	7	PRESENCE#	8	PORT2L	9	PORT2R	10	SENSE2_R																				
Pin	Define	Pin	Define																																										
1	PROT1L	2	SENSE1_R																																										
3	AGND	4	SENSE_S																																										
5	PROT1R	6	NC																																										
7	PRESENCE#	8	PORT2L																																										
9	PORT2R	10	SENSE2_R																																										
SPEAK	 <table border="1"> <thead> <tr> <th>Pin</th> <th>Define</th> <th>Pin</th> <th>Define</th> </tr> </thead> <tbody> <tr> <td>1</td> <td>SPKOUT_L-</td> <td>2</td> <td>SPKOUT_L+</td> </tr> <tr> <td>3</td> <td>SPKOUT_R-</td> <td>4</td> <td>SPKOUT_R+</td> </tr> </tbody> </table>	Pin	Define	Pin	Define	1	SPKOUT_L-	2	SPKOUT_L+	3	SPKOUT_R-	4	SPKOUT_R+																																
Pin	Define	Pin	Define																																										
1	SPKOUT_L-	2	SPKOUT_L+																																										
3	SPKOUT_R-	4	SPKOUT_R+																																										
DC_IN DC_IN2																																													
MSATA																																													
CPU_FAN1																																													
HDMI	 <table border="1"> <thead> <tr> <th>Pin</th> <th>Define</th> <th>Pin</th> <th>Define</th> </tr> </thead> <tbody> <tr> <td>1</td> <td>TMDS data 2+</td> <td>2</td> <td>TMDS data shield</td> </tr> <tr> <td>3</td> <td>TMDS data 2-</td> <td>4</td> <td>TMDS data 1+</td> </tr> <tr> <td>5</td> <td>TMDS data shield</td> <td>6</td> <td>TMDS data 2-</td> </tr> <tr> <td>7</td> <td>TMDS data 0+</td> <td>8</td> <td>TMDS data shield</td> </tr> <tr> <td>9</td> <td>TMDS data 0-</td> <td>10</td> <td>TMDS clock+</td> </tr> <tr> <td>11</td> <td>TMDS clock shield</td> <td>12</td> <td>TMDS clock-</td> </tr> <tr> <td>13</td> <td>CEC</td> <td>14</td> <td>No connectde</td> </tr> <tr> <td>15</td> <td>DDC clock</td> <td>16</td> <td>DDC data</td> </tr> <tr> <td>17</td> <td>Groud</td> <td>18</td> <td>+5V power</td> </tr> <tr> <td>19</td> <td>Hot plug detect</td> <td></td> <td></td> </tr> </tbody> </table>	Pin	Define	Pin	Define	1	TMDS data 2+	2	TMDS data shield	3	TMDS data 2-	4	TMDS data 1+	5	TMDS data shield	6	TMDS data 2-	7	TMDS data 0+	8	TMDS data shield	9	TMDS data 0-	10	TMDS clock+	11	TMDS clock shield	12	TMDS clock-	13	CEC	14	No connectde	15	DDC clock	16	DDC data	17	Groud	18	+5V power	19	Hot plug detect		
Pin	Define	Pin	Define																																										
1	TMDS data 2+	2	TMDS data shield																																										
3	TMDS data 2-	4	TMDS data 1+																																										
5	TMDS data shield	6	TMDS data 2-																																										
7	TMDS data 0+	8	TMDS data shield																																										
9	TMDS data 0-	10	TMDS clock+																																										
11	TMDS clock shield	12	TMDS clock-																																										
13	CEC	14	No connectde																																										
15	DDC clock	16	DDC data																																										
17	Groud	18	+5V power																																										
19	Hot plug detect																																												

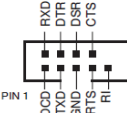
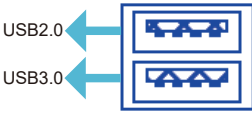
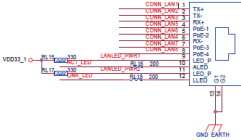
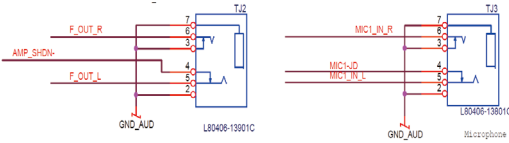

COM1	
USB2.0 USB3.0	
TJ1 YJ2	
Mic-in/Line-out	

\*Other Matters Please consult the sales.